

PowerGen Remote Power Series



Authorized Distributor



Qnergy

Renewable. Reliable. Resilient.

PowerGen Series

Designed for rugged and remote operation, the PowerGen remote power generator provides reliable electrical power supply to the most demanding and mission-critical loads. Based on Qnergy's no-maintenance and highly reliable PCK series Stirling engines, the generator package can work seamlessly with a variety of fuel supplies, including: natural gas, propane, ethane, biogas, and multiple associated gas streams. By means of its flexible and modular design, this generator package can be tailored to provide a broad range of power output architectures to meet the electrical requirements of each specific site load.

Assembled using lean manufacturing processes, the PowerGen is built to meet strict quality standards. The integrated components and controls are all designed to maximize the customer's ability to control and monitor their power-generation asset while minimizing servicing of any kind.



Benefits

- | | |
|----------------------------------|----------------------------|
| Prime Power Solution | High Efficiency |
| Low Cost of Ownership | Multiple Fuel Options |
| Unprecedented Reliability | Plug and Play Installation |
| Suitable for Rugged Applications | Small Footprint |
| Load Following | Hybrid Capabilities |

What Makes Qnergy PowerGen Your Remote Power Solution?

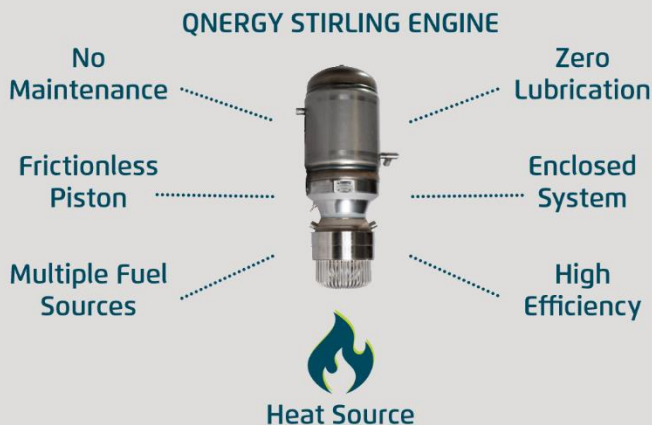

Each PowerGen Remote Power System utilizes Qnergy's unique PCK80 Stirling Generator

APPLICATIONS

- Artificial Lift
- Communication & SCADA
- Monitoring, Security & Safety
- Prime Power
- Renewable Hybrid
- Well Pad Automation
- Cathodic Protection (ICCP)

Qnergy has an experienced design and integration team that works to meet customer specific power needs!



PowerGen Specification	5650 Series	1800 Series	1200 Series	600 Series
Power Output*	5,650 Watts	1,800 Watts	1,200 Watts	600 Watts
Fuel Type	Gaseous Fuels: NG, LPG, Propane, Wellhead Gas			
Fuel Consumption (max)	3,964 ft ³ /day (NG) 44.4 gal/day (Propane)	1,300 ft ³ /day (NG) 10 gal/day (Propane)	935 ft ³ /day (NG) 7.2 gal/day (Propane)	550 ft ³ /day(NG) 4.3 gal/day (Propane)
Fuel Pressure Range	3-50 PSI (Natural Gas) 2-10 PSI (Propane)			
Caloric Value (min / max)	751/3,382 BTU/ft ³			
Ambient Temperature Operation** Ambient Temperature Rated (Startup)	-13°F to 122°F 5°F to 122°F			
Cabinet Electrical Rating***	IP54			
Electrical Configuration	120/240 VAC Split Phase			
Certification	cETLus (UL2200) (CSA C22.2#100/C22.2#14)e3w			
Dry Weight	866 lbs (392 kg)			

Additional Feature Options:

- Glycol Heat Trace
- Extreme Low Temperature Module
- Remote Monitoring
- Extended Standby
- Impressed Current Cathodic Protection
- Three Stage Battery Charging
- Configurable Voltage Outputs
- Gas Pressure Reduction System
- Custom Enclosure Color
- Fuel Conditioning
- Hybrid Compatible
- Sour Gas Service
- Heat Recovery
- Enhanced Security

* For detailed performance data, please request the engineering specification document

** Ask about a low temperature operation package (down to -40°F)

*** Additional electrical output configurations available

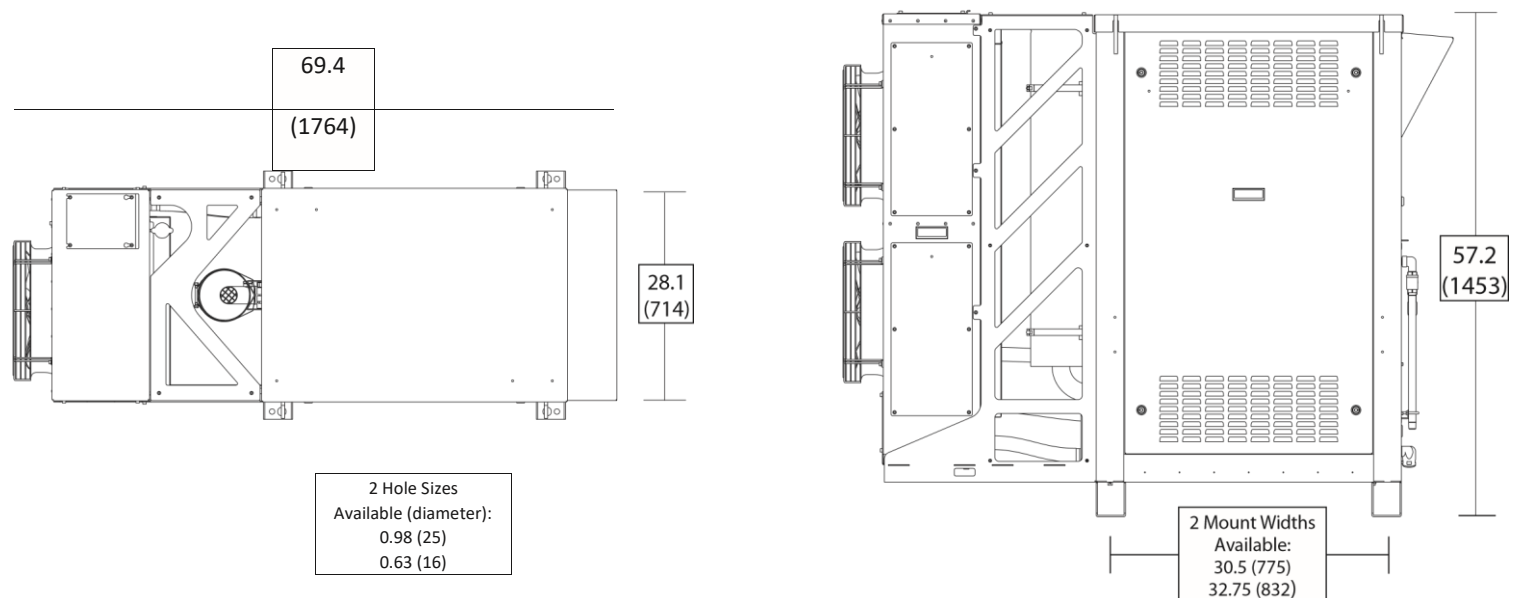

PowerGen Remote Power Series

OilPro is the Canadian servicing and stocking Distributor for Qnergy. Qnergy (q-ner-gy) is a company focused on providing ultrareliable power solutions. Their technology is rugged, cost-effective, and efficient. With more than 40 years of expertise and proven reliability, Qnergy brings proprietary, high-performance Free-Piston Stirling Engine technology to the market to integrate within commercial and industrial applications.



<https://oilpro.ca/product/powergen/>